

User Manual for Terabee IND-TOF-1



Table of contents

1. Introduction	4
1.1. About Terabee IND-TOF-1	4
1.2. Technical specifications	5
1.3. Symbols explanation	6
2. Package contents	7
3. Mechanical integration	8
3.1. Mechanical design and mounting	8
3.2. Operating buttons and indicators	11
3.3. M12 connector pinout	12
3.4. DC Electrical characteristics	13
4. Operating modes	14
4.1. Operating mode overview	14
4.2. Sensor setup phases	16
4.3. Operating mode 1 (default)	16
4.3.1. Description	16
4.3.2. Set up	17
4.3.3. Operation	18
4.3.4. LED signalization sequence	18
4.4. Operating mode 2	19
4.4.1. Description	19
4.4.2. Set up	19
4.4.3. Operation	20
4.4.4. Rolling buffer (5 measurements)	20
4.4.5. LED signalization sequence	21
4.5. Operating mode 3	21
4.5.1. Description	21
4.5.2. Set up	22
4.5.3. Operation	23
4.5.4. LED signalization sequence	25
4.6. Operating mode 4	25
4.6.1. Description	25
4.6.2. Set up	25
4.6.3. Operation	26
4.6.4. Rolling buffer (5 measurements)	28
4.6.5. LED signalization sequence	28
4.7. Operating mode 5	29
4.7.1. Description	29
4.7.2. Setup	29

4.7.3. Operation	30
4.7.4. Rolling buffer (5 measurements)	32
4.8. Operating mode 6 (Ranging mode)	33
4.8.1. Description	33
4.8.2. Set up	33
4.8.3. Operation mode	33
4.9. Switching between modes, threshold transfer	34
4.10. Error cases	35
4.11. Special cases (applicable only to modes 3 and 4)	36
4.11.1. Special case 1	36
4.11.2. Special case 2	36
5. Communication	38
5.1. RS485 interface settings	38
5.2. Input registers (read-only)	38
5.2.1 New distance flag	38
5.2.2 Circular distance buffer (applicable for modes 2, 4 and 5)	38
5.3. Configurable sensor parameters (holding registers)	39
5.3.1. Device addressing setting	39
5.3.2. Menu timeout	39
5.3.3. Time delay for operation mode	39
5.3.4. NO/NC active region (applicable to mode 3, 4 and 5)	40
5.3.5. Operating mode select	40
5.3.6. Mode 5 limit value select	41
5.3.7. NO/NC on time (applicable to mode 2, 4 and 5)	41
5.3.8. Fly zone select	41
5.3.9. NPN/PNP selected	41
5.3.10. NO/NC selected	42
5.3.11. Background distance	42
5.3.12. Threshold 1 distance	42
5.3.13. Threshold 2 distance	42
5.4. Default factory reset	43
6. Optical characteristics	44
6.1. Projected reception area	44
6.2. Field of View characteristics	44
7. Connection example: input to a PLC	46
7.1. PNP connection	46
7.2. NPN connection	47
8. Compliance	48

1. Introduction

The purpose of this document is to give guidelines for installation, use and integration of the Terabee IND-TOF-1 distance sensor. The user manual includes instructions on the six modes: setup and operation. For guidelines on sensor connection and usage with a personal computer, please refer to [Terabee IND-TOF-1 Connection to Personal Computer \(Guide\)](#).

1.1. About Terabee IND-TOF-1

The Terabee IND-TOF-1 distance sensor offers 12.5 meter detection capabilities with a Field of View of 2° using Time-of-Flight technology. The rugged IP65 enclosure ensures dust-proof and water-resistant operation, while the sensor's compact form-factor (99 g) allows installation in places not possible with larger & heavier sensors.

Programmable distance thresholds can be set using integrated teach-in buttons to trigger alarms, detect presence and movement, count objects and more. The sensor provides proximity notification with a classic NO/NC switching output, while also communicating calibrated distance data via RS485 (Modbus) interface. Six operating modes enable you to address a variety of distance sensing and monitoring applications!



Figure 1. Terabee IND-TOF-1

It takes as little as 5 seconds to set up a switching threshold and customized trigger zones for proximity notification using the integrated teach-in buttons. Multi-color LEDs provide a visual confirmation of distance threshold breach, sensor power and live data transfer, making setup easy and intuitive.

For Terabee IND-TOF-1 sensor purchase please visit the [official product page](#) of the Terabee website or contact terabee-sales@terabee.com.

1.2. Technical specifications

Table 1 - Technical specifications of Terabee IND-TOF 1

Product code	TB-IND-TOF-1-RS485
Performance	
Detection principle	Infrared Time-of-Flight
Range ⁽¹⁾	0.5 m to 12.5 m
Output resolution	5 mm
Accuracy ⁽¹⁾	±4 cm in the first 4 m, ±1% beyond 4 m
Repeatability	±5 mm
Field of View	Approx. 2°
Projected reception area	10.5 cm × 10.5 cm @ 3 m range
Light source wavelength	940 nm
Access time for distance measurements	11 ms
Response time for NO/NC state change ⁽³⁾	35 ms to 100 ms
Electronics	
Supply voltage V_{IN}	24 V $\pm 5\%$ DC
Current consumption (max. @ V_{IN} = 24V DC)	90 mA
Warm-up time (advised)	≥ 15 min
Initialization time	< 1 s
Interfaces	
Digital output	Switching (NO/NC in PNP/NPN configuration), 0 V - 24 V Maximum output current: 450 mA (@ V_{IN} = 24 V DC), unfused
Serial interface (distance measurement and remote settings)	RS485 (half-duplex, 19.2 kbps)
Communication protocol	Modbus
Visual notification	5 x LEDs (multicolor)
Mechanical data	
Dimensions (L×W×H)	94 mm x 56 mm x 31 mm
Weight	99 g
Enclosure rating	IP65

Housing material	Main body: ABS Backplate: Aluminium
Type of connection	M12 A-coded male connector, 5-pin
Ambient temperature operation (@ $V_{IN} = 24\text{ V DC}$)	-20°C to +45°C
Mounting style	4 slots for M4 screws
Conformity	
Reference standard	CE, RoHS, Eye-Safety, Vibration & Shock ⁽⁴⁾

(1) Specifications are derived from tests in controlled conditions (target with 80% diffuse reflectivity, indoor fluorescent lighting, ambient temperature around 25°C). Note that bright sunlight, target surface reflectivity and other variables can affect sensor performance

(2) Evaluated as one standard deviation over multiple measurements

(3) Applicable to modes 1 and 3

(4) Refer to conformity certificates in the User Manual for details

1.3. Symbols explanation

The following symbols are used within the document:



This symbol indicates specific recommendations in order to run the sensor in the intended way

2. Package contents

The product package (Figure 2) contains the following items:

- Terabee IND-TOF-1 distance sensor



Figure 2. Product package content

3. Mechanical integration

3.1. Mechanical design and mounting

Terabee IND-TOF-1 distance sensor offers an ABS housing and an aluminium backplate (part of sensor housing) for robust mounting. Figure 3 illustrates external dimensions of the distance sensor.

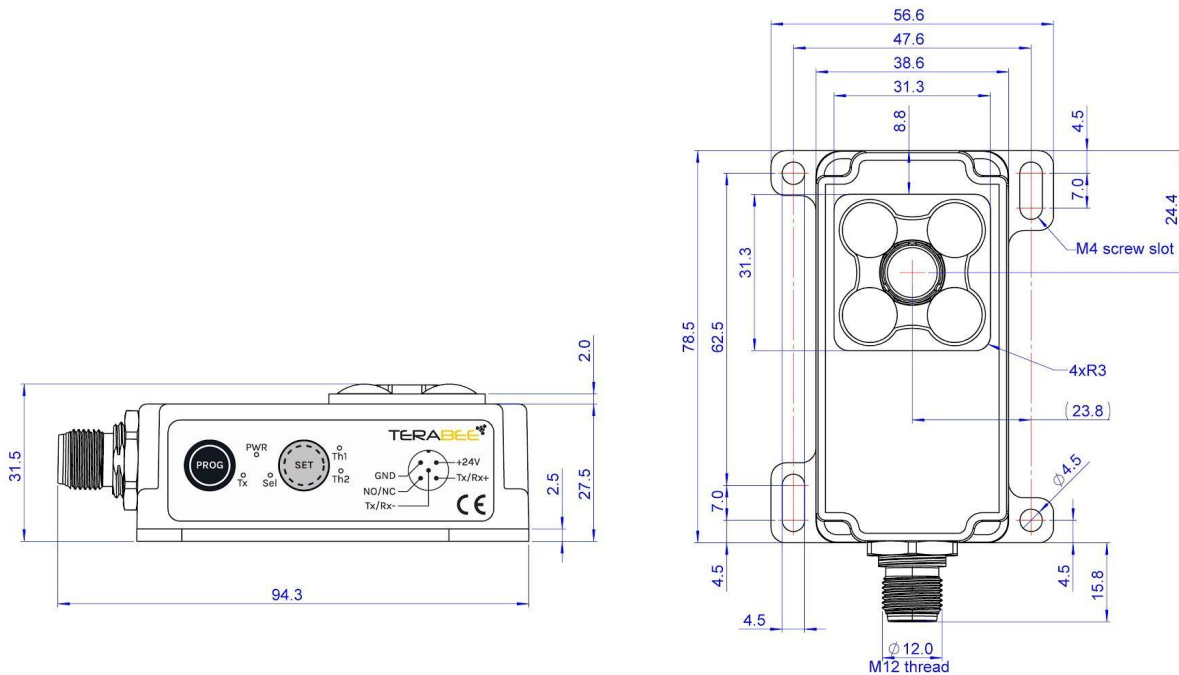

Figure 3. External dimensions of Terabee IND-TOF-1

The bottom casing part includes four slots for mounting the sensor using standard M4 screws. The following methods can be used to mount the Terabee IND-TOF-1:

1. Front-panel mount using the long M4 screw slots (Figure 4)
2. Back-panel mount using the 2mm ledge on the front side of the sensor (Figure 5)

The first solution allows for easy surface attachment and rapid evaluation of the sensor. Depending on the application requirements for connector/cable position, the sensor can be mounted both horizontally and vertically. The second solution offers the possibility to mount the sensor behind a surface (e.g. panel), ideally with 2 mm to 3 mm thickness - for a more integrated look. Please note that mounting components (e.g. screws, nuts, etc.) are not included in the product packaging.



Figure 4. Front-panel mounting example

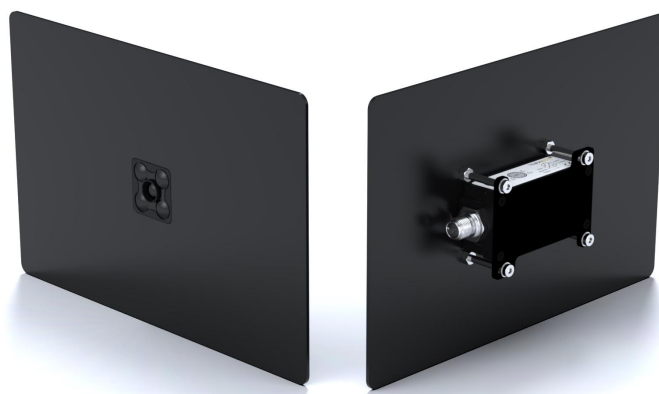
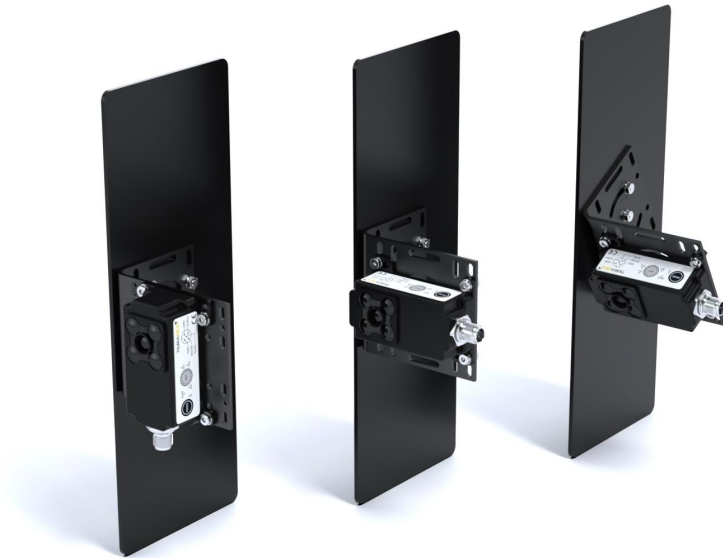

Figure 5. Back-panel mounting example

An optional 90 degree mounting bracket accessory is also available on the [Terabee website](#) for angled attachment methods to existing industrial infrastructures.



When choosing a place for installation, please consider the following recommendations:

- *During setup and operation, please make sure that the sensor is not pointing at a distance longer than the maximum offered range (12.5 meters). Please ensure that a physical object/obstruction (e.g wall) is covering the sensors entire Field of View, no further than the maximum range (12.5 meters) of the sensor*
- *It is recommended to install the sensor min. 70 cm from the measuring/monitoring objects in your application. Please note that mounting the sensor with a distance smaller than 70 cm from the measured object, can affect the sensor absolute accuracy*
- *Mounting close to sources of heat or strong electromagnetic fields can decrease the sensing performance*
- *Do not mount anything directly in front of the sensor*
- *Within the first meter from the sensor avoid objects with high surface reflectivity in a cone of approximately $\pm 45^\circ$ around the central optical axis of the sensor*
- *It is better to avoid having other sources of continuous wave or modulated IR light close to the sensor*

3.2. Operating buttons and indicators

The sensor features integrated teach-in buttons (**PROG** and **SET**) to allow quick and intuitive on-the-field programming of distance thresholds (see Section 4 for mode setup and operation). Onboard multi-color LEDs provide a visual confirmation of distance threshold breach, sensor power and more. [Figure 6](#) and the corresponding [Table 2](#) describe the connector location, onboard operating buttons and indicators. [Table 3](#) shows the signalization sequence of the LEDs.

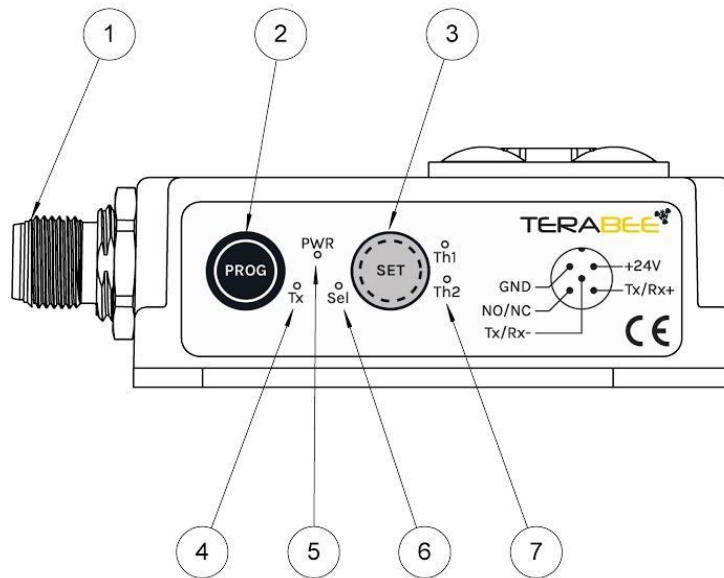

Figure 6. Operating buttons and LED indicators

Table 2 - Connector location and onboard operating buttons and indicators

No.	Category	Designator	Description
1	Connection	M12 connector	A-coded male, 5 pin
2	Teach-in button	PROG	Background distance threshold setup (enter setup mode)
3	Teach-in button	SET	Threshold No.1 and No. 2 setting
4	LED indicator	Tx	RS485 data transmission
5	LED indicator	PWR	Power indicator
6	LED indicator	Sel	Notification on device selection by master
7	LED indicators	Th1, Th2	Error and threshold breach notification

Table 3 - LED signalization logic

LED indicator	LED Color	Signalization logic
Tx	Red	LED blinking indicates that sensor (slave) is sending data on the bus
PWR	Red	LED continuously ON whenever connected to a power supply
Sel	Blue	LED blinking indicates that sensor (slave device) has been selected by a master
Th1, Th2	Green/Red	Distance threshold breach notification, error indication

3.3. M12 connector pinout

Terabee IND-TOF-1 uses an M12 A-coded male connector, 5 pins. [Figure 7](#) and [Table 4](#) provides an overview of the connector pinout.

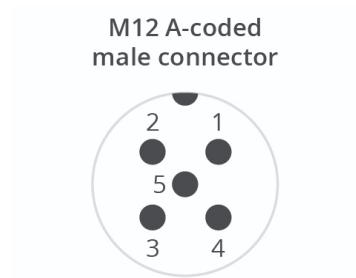

Figure 7. M12, 5-pin connector pinout layout

Table 4 - Connector pinout description

Pin	Designator	Description
1	+24V	24V DC power supply
2	GND	Ground (power supply and data)
3	NO/NC	Normally Open or Normally closed (PNP/NPN) connection
4	Tx/Rx+	RS485 differential line. High for logic 1 and low for logic 0
5	Tx/Rx-	RS485 differential line. Low for logic 1 and high for logic 0

3.4. DC Electrical characteristics

Table 5 - DC Electrical characteristics

	Parameter	Minimum	Standard	Maximum
Power supply	Voltage input DC	24 V	24 V	24 V
	Current consumption	50 mA	70 mA	90 mA
Digital output levels NO/NC (in PNP/NPN)	Voltage output DC	0 V		24 V
	Current consumption			450 mA

4. Operating modes

The sensor features 6 embedded operating modes for (1) proximity notification; using a classic NO/NC (0-24V) switching output and (2) providing information of distance data.

Operating modes 1 to 5 output a 24V signal on the NO/NC pin according to user programmable settings. On the field programming makes it quick and easy to set up distance thresholds using integrated teach-in buttons (**PROG** and **SET**), allowing to customize trigger zones and meet specific application needs.

While all operating modes support distance data communication via RS485 interface at all times, operating mode 6 has been developed to obtain only distance values without the use of programmable switching thresholds.

Since the sensor's NO/NC switching output and RS485 distance data use distinct pins, both functions can be used either to complement each other or as separate functions. For instance, the switching output can act as a trigger for the master device, e.g. Programmable Logic Controller (PLC), to inquire the exact distance at which the light beam has been broken.





Please respect the sensor warm up time (at least 15 mins), before operating mode setup and sensor operation. Using the sensor before the recommended warm-up time may negatively impact its performance.

4.1. Operating mode overview

Operating modes are summarized in [Table 6](#). Operating modes from 1 to 5 - provide detection zones with distance thresholds functionalities and switching output, and require a setup process, before going into operation mode. Mode 6 requires no setup and offers no switching output, and distance data sampling is started as soon as the sensor is powered.

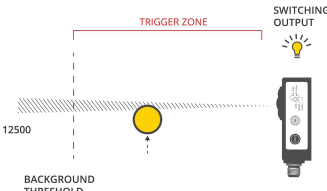
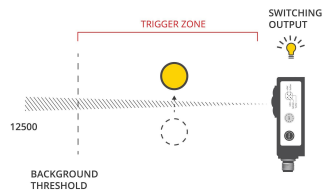
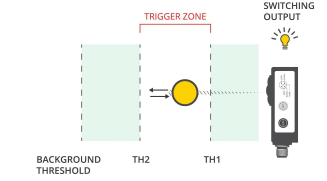
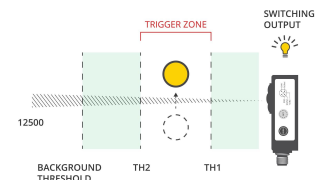
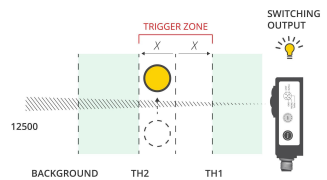
Table 6 - Operating modes

Operating mode	Setup	Operation	
		Switching output (NO/NC)	Distance data
<p>1</p> 	1 threshold	<p>Output is triggered as soon as an object BREAKS the light beam in the trigger zone.</p> <p>Output remains triggered as long as the light beam in the trigger zone is broken.</p>	Available via RS485 (Modbus)
<p>2</p> 	1 threshold	<p>Output is triggered as soon as an object LEAVES the light beam in the trigger zone. *</p>	Available via RS485 (Modbus)
<p>3</p> 	3 thresholds	<p>Output is triggered as soon as an object ENTERS the trigger zone.</p> <p>Output remains triggered as long as the light beam in the trigger zone is broken.</p>	Available via RS485 (Modbus)
<p>4</p> 	3 thresholds	<p>Output is triggered as soon as an object LEAVES the trigger zone of the light beam. *</p>	Available via RS485 (Modbus)
<p>5</p> 	3 thresholds	<p>Output is triggered as soon as an object LEAVES the trigger zone of the light beam. *</p>	Available via RS485 (Modbus)
<p>6</p> 	No setup	No switching output	Available via RS485 (Modbus)

* The sensor is not triggered while the light beam in the trigger zone is broken (applicable to modes 2, 4 and 5)

4.2. Sensor setup phases

The setup process always consists of 3 phases, displayed in [Figure 8](#).

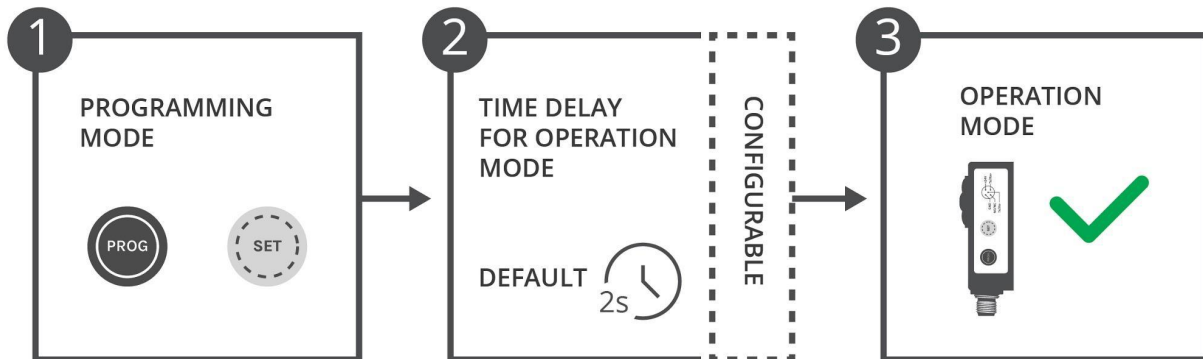

Figure 8. Setup phases

1. **Programming mode** - registration of distance thresholds (valid thresholds are set)
2. **Time delay for operation mode** - wait period between “end of programming mode” and “start of operation mode” (default value is set to 2 seconds, however this is a configurable parameter)
3. **Operation mode** - marks the end of setup, sensor is ready to perform detection under programmed trigger zones.



Please be aware that during setup a timeout (default 30 s), is initiated at any step of the following setup procedures. If such timeout expires, the sensor will exit the Setup (programming) mode and go back into Operation mode. To modify the timeout value (MENU TIMEOUT parameter) please see [Section 5.3.3](#).

4.3. Operating mode 1 (default)

4.3.1. Description

This mode is used for reactive detection applications with the switching output triggered as soon as an object enters the light beam in the trigger zone. A background threshold is programmed to set the trigger zone. Mode 1 is useful for alarm applications, positioning tasks and monitoring distance.

4.3.2. Set up

MODE 1

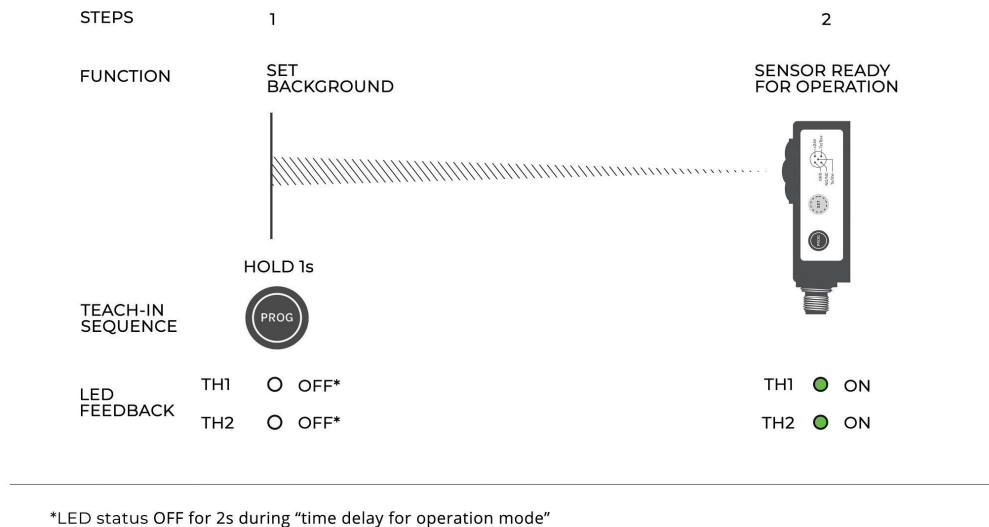

Figure 9. Mode 1 setup phases

Step 1 - Set background threshold

- Make sure that an object is fully covering the sensors Field of View at the preferred background distance, then hold the PROG button for 1 second
- The LED indicators, Th1 and Th2 (both GREEN), will now go from ON to OFF status to confirm entering programming mode.
- Once the programming mode is completed, the sensor enters the "time delay for operation mode" for 2 seconds (default). See [Section 5.3.3.](#) to configure this parameter.
- After that, LED indicators, Th1 and Th2, will turn ON and stay fixed (GREEN) to verify a properly stored background threshold.

Step 2 - Sensor ready

- The background is now taught in and the sensor is in operation mode.



During setup and operation, please make sure that the sensor is not pointing at a distance longer than the maximum offered range (12.5 meters). Please ensure that a physical object/obstruction (e.g wall) is covering the sensors entire Field of View, no further than the maximum range (12.5 meters) of the sensor.

4.3.3. Operation

As soon as an object or a person enters the light beam in the set trigger zone, a switching output is triggered. The sensor is activated as long as an object or a person is detected in the light beam of the trigger zone. Both LED indicators, Th1 and Th2 will stay continuously ON (RED) as long as the output is triggered. Any movement beyond the background threshold will be ignored.

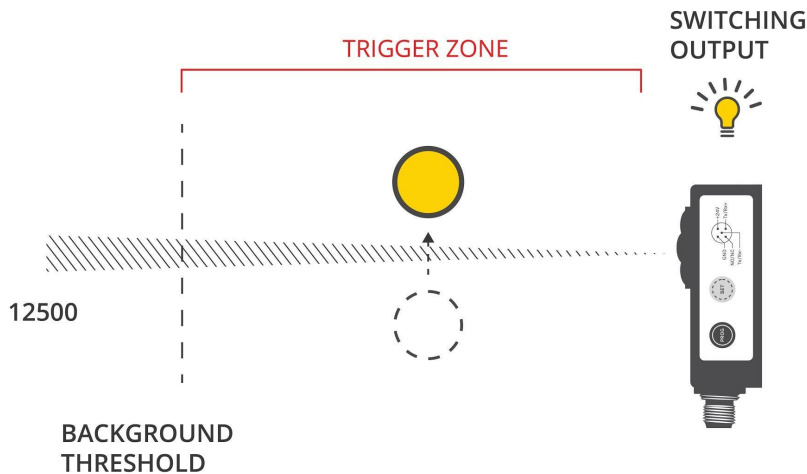

Figure 10. Mode 1 operation, detection principle

4.3.4. LED signalization sequence

Table 7 - Mode 1 LED signalization sequence

Phase	LED designators	Sequence	Signification
Setup	Th1; Th2	Both LEDs will go from ON (GREEN) to OFF status for 2 s (default)	Indicates a properly stored background distance
	Th1; Th2	Both LEDs will stay continuously ON (GREEN)	Indicates that setup is finalized and sensor is in operation mode
Operation	Th1; Th2	Both LEDs will stay continuously ON (RED)	Indicates that an object is detected within the set trigger zone. LEDs will stay RED as long as the object is in the Field of View

4.4. Operating mode 2

4.4.1. Description

Mode 2 is used for applications such as counting moving objects/people, and monitoring object height. A single background threshold is used to set a trigger zone. The sensor is activated as soon as an object leaves the programmed trigger zone in the light beam.

4.4.2. Set up

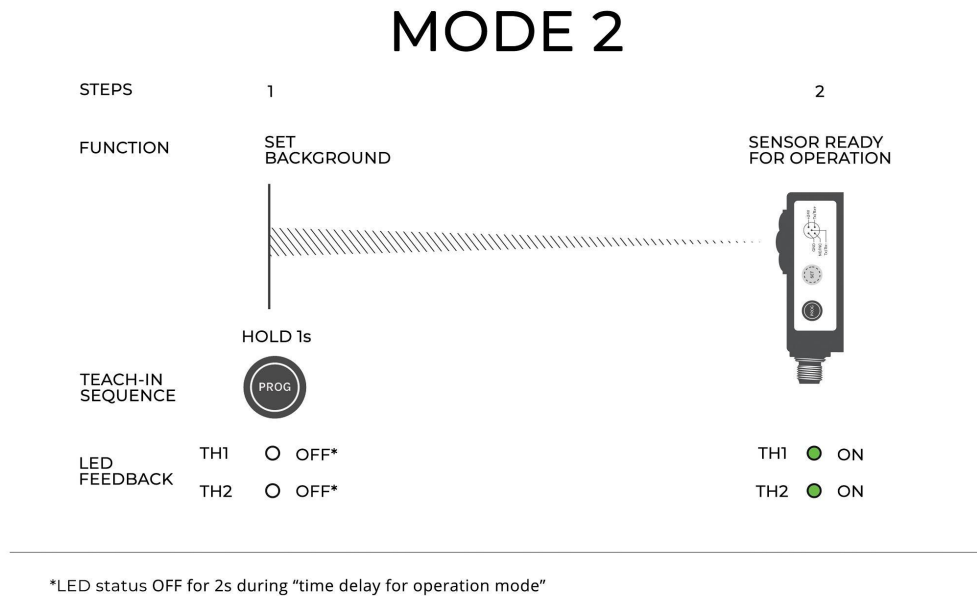

Figure 11. Mode 2 setup phases

Step 1 - Set background threshold

- Make sure that an object is fully covering the sensors Field of View at the preferred background distance, then hold the PROG button for 1 second.
- The LED indicators, Th1 and Th2 (both GREEN), will now go from ON to OFF status to confirm entering programming mode.
- Once the programming mode is completed, the sensor enters the "time delay for operation mode" for 2 seconds by default (see [Section 5.3.3.](#) to configure this parameter).
- After that, LED indicators, Th1 and Th2, will turn ON and stay fixed (GREEN) to verify a properly stored background threshold.

Step 2 - Sensor ready

- The background is now taught in and the sensor is in operation mode.



During setup and operation, please make sure that the sensor is not pointing at a distance longer than the maximum offered range (12.5 meters). Please ensure that a physical object/obstruction (e.g wall) is covering the sensors entire Field of View, no further than the maximum range (12.5 meters) of the sensor.

4.4.3. Operation

Unlike mode 1, a switching output will not be activated while an object is in the sensors trigger zone. In mode 2, as soon as an object or a person completely leaves the sensors trigger zone in the light beam (measured distance reads the background threshold distance) - a switching output is activated. Both LED indicators, Th1 and Th2, will blink GREEN once to indicate a detection. Any movement beyond the background threshold will be ignored.

The NO/NC switching output activation time by default is set to 250 ms, and can be modified using the "NO/NC on time" parameter (see [Section 5.3.7.](#))

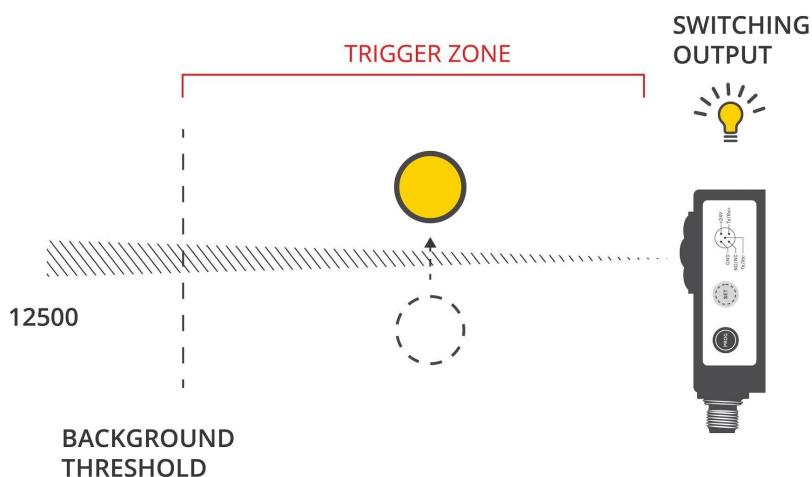

Figure 12. Mode 2 operation, detection principle

4.4.4. Rolling buffer (5 measurements)

After an object has entirely left the light beam of the trigger zone, the distance that was recorded during detection, is stored in a register as **the measured distance to the object**. The sensor has the capacity to store 5 measurements at the same time. Every new measurement will erase the oldest (5th) value from the device. This functionality allows to obtain accurate distance-to-target feedback as an added layer of intelligence, in addition to the NO/NC switching output. Please refer to [Section 5.2.2.](#) for additional information.

4.4.5. LED signalization sequence

Table 8 - Mode 2 LED signalization sequence

Phase	LED designators	Action	Function
Setup	Th1; Th2	Both LEDs will go from ON (GREEN) to OFF status for 2 s (default)	Indicates a properly stored background distance
	Th1; Th2	Both LEDs will stay continuously ON (GREEN)	Indicates that setup is finalized and sensor is in operation mode
Operation	Th1; Th2	Both LEDs will blink GREEN once	Indicates that an object has just left the Field of View

4.5. Operating mode 3

4.5.1. Description

In mode 3, a switching window is taught in between the sensor and the background threshold. The sensor is activated as soon as an object or a person enters the selected trigger zone(s). This mode is used for monitoring a frontal approach or level fulfilment, for instance.



Please note that mode 3 is not recommended for monitoring lateral movement or detecting small objects. Obstacles that partially enter the sensors Field of View may be detected at an incorrect distance, caused by an averaging effect (refer to [Section 6.2.](#))

4.5.2. Set up

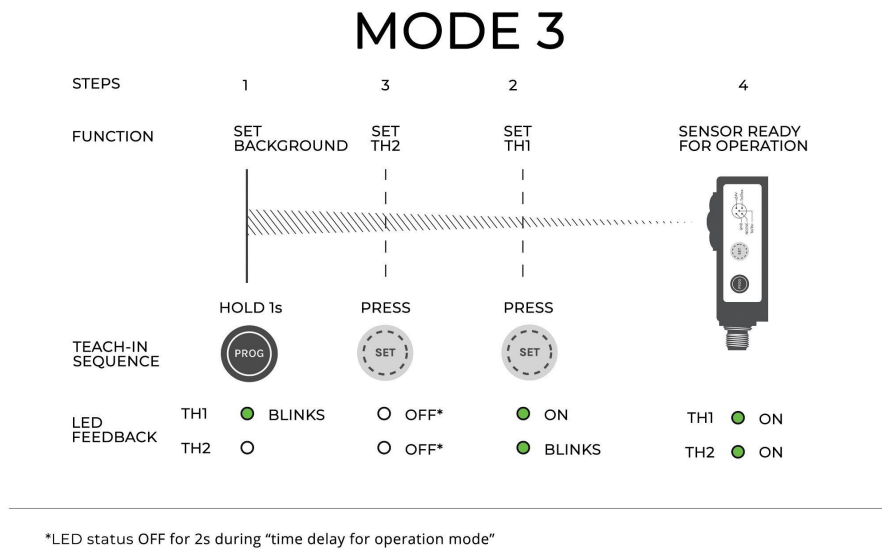

Figure 13. Mode 3 setup phases.

Step 1 - Set background threshold

- Make sure that an object is fully covering the sensors Field of View at the preferred background distance, then hold the PROG button for 1 second.
- The background threshold is now stored and the LED indicator, Th1, will start blinking GREEN to signal that the sensor is ready for Threshold 1 (Th1) setup.

Step 2 - Set Threshold 1 (Th1)

- Make sure that an object is fully covering the sensors Field of View at the preferred Threshold 1 (Th1) distance, then press the SET button.
- The LED indicator, Th1, will now stay continuously ON (GREEN) to verify a properly stored threshold.
- The LED indicator, Th2, will start blinking GREEN to signal that the sensor is ready for Threshold 2 (Th2) setup.

Step 3 - Set Threshold 2 (Th2)

- Make sure that an object is fully covering the sensors Field of View at the preferred distance, **greater than threshold 1**, then press the SET button.
- The LED indicator, Th2, will continuously stay ON (GREEN) to verify a properly stored threshold.
- Once both thresholds are registered, the sensor will go into "Time delay for Operation mode" for 2 seconds (default), before initializing operation mode. LED

indicators, Th1 and Th2, will turn OFF during the “Time delay for operation mode”. See [Section 5.3.3](#). for more information on configurable parameters.

Step 4 - Sensor ready

- After the time delay, both LED indicators, Th1 and Th2 will stay continuously ON (GREEN) to signal the setup is finalized and the sensor is in operation mode.



During setup and operation, please make sure that the sensor is not pointing at a distance longer than the maximum offered range (12.5 meters). Please ensure that a physical object/obstruction (e.g wall) is covering the sensors entire Field of View, no further than the maximum range (12.5 meters) of the sensor.

4.5.3. Operation

Mode 3 enables proximity notification using 3 distance thresholds. As soon as an object enters the light beam of the trigger zone, a switching output is activated. The sensor will stay activated as long as the object remains in the set trigger zone. Any movement beyond the background threshold will be ignored.

By default, mode 3 offers detection capabilities with a switching window, where the active trigger zone is between Threshold 1 and Threshold 2. By changing the NO/NC active region setting in sensor parameters (see [Section 5.3.4](#).), the user can also set multiple trigger zones in the sensors light beam: (1) from min. sensor distance (50 cm) to Threshold 1 and, (2) from Threshold 2 to Background Threshold. Please consult figures below for visual instructions.

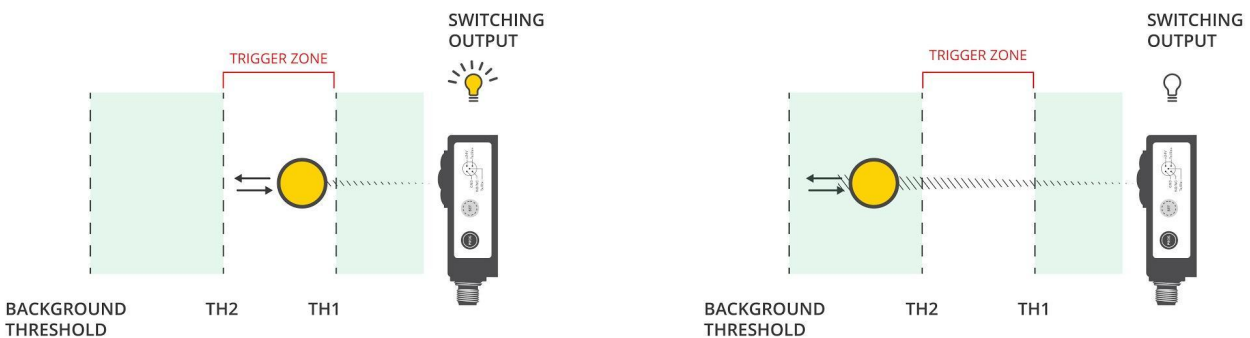

Figure 14. Mode 3 operation for NO/NC Active region = 0 (default value) ⇒ Only white patched area (Th1 < distance < Th2) is triggering the switching output

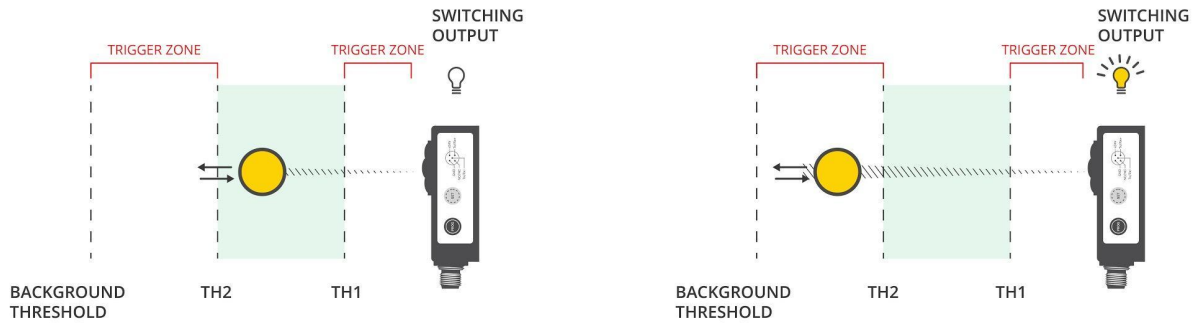

Figure 15. Mode 3 operation for NO/NC Active region = 1 ⇒ Only white patched areas (Th2 < distance OR distance < Th1) are triggering the switching output

The following table summarizes the detection model for mode 3.

Table 9 - NO/NC active regions for mode 3

Location of detection	LED indication / color	Switching output status (NO/NC active region = 0)	Switching output status (NO/NC active region = 1)
Between the sensors minimum distance (50 cm) and the Threshold 1	Th1 stays continuously ON / RED	OFF	ON
Between Threshold 1 and Threshold 2	Th1 and Th2 continuously blinking / GREEN	ON	OFF
Between the Threshold 2 and the Background threshold	Th2 stays continuously ON / RED	OFF	ON
Greater than or at background threshold distance	Th1 and Th2 stay continuously ON / GREEN	OFF	OFF

4.5.4. LED signalization sequence

Table 10 - Mode 3 LED signalization sequence

Phase	LED designators	Action	Function
Setup	Th1	LED continuously blinking GREEN	Indicates a properly stored background distance and to signal that the device is ready for Threshold 1 setup
	Th2	LED starts continuously blinking (GREEN)	Indicates a properly stored Threshold 1 distance and signals that the device is ready for Threshold 2 registration
	Th1	LED continuously on (GREEN)	Indicates that setup is finalized and sensor is in operation mode.
	Th1; Th2	LEDs stay continuously ON (GREEN)	

4.6. Operating mode 4

4.6.1. Description

In mode 4, a background threshold along with a switching window are taught in. The sensor is activated as soon as an object leaves the light beam of the selected trigger zone(s). This mode is used for object or vehicle height monitoring as well as object sorting for size.

4.6.2. Set up

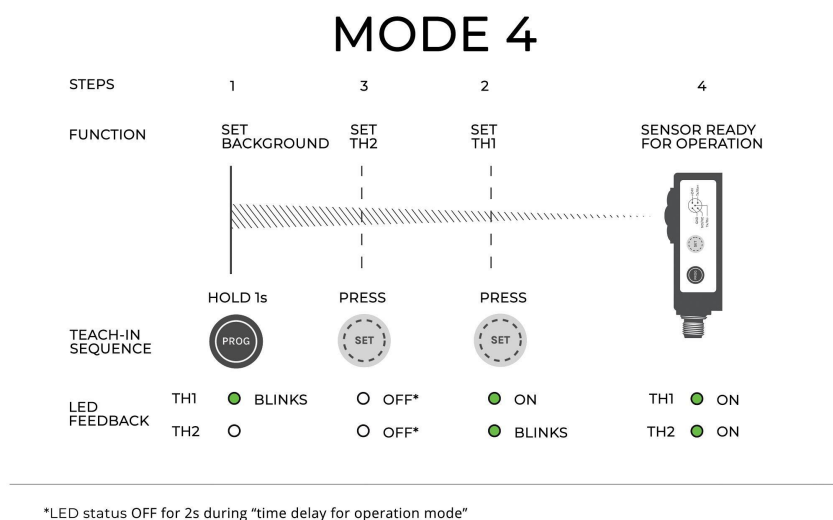

Figure 16. Mode 4 setup phases.

Step 1 - Set background threshold

- Make sure an object is fully covering the sensors Field of View at the preferred distance, then hold the PROG button for 1 second.
- The background threshold is now stored and the LED indicator, Th1, will start blinking GREEN to signal that the sensor is ready for Threshold 1 (Th1) setup.

Step 2 - Set Threshold 1 (Th1)

- Make sure an object is fully covering the sensors Field of View at the preferred distance, then press the SET button.
- The LED indicator, Th1, will stay continuously ON (GREEN) to verify a properly stored threshold.
- The LED indicator, Th2, will start blinking GREEN to signal that the sensor is ready for Threshold 2 (Th2) setup.

Step 3 - Set Threshold 2 (Th2)

- Make sure that an object is fully covering the sensors Field of View at the preferred distance, **greater than threshold 1**, then press the SET button.
- The LED indicator, Th2, will continuously stay ON (GREEN) to verify a properly stored threshold.
- Once both thresholds are registered, the sensor will go into "Time delay for Operation mode" for 2 seconds (default), before initializing operation mode. LED indicators, Th1 and Th2, will now turn OFF during the "Time delay for operation mode". See [Section 5.3.3](#) for more information on configurable parameters.

Step 4 - Sensor ready

- After the time delay, both LED indicators, Th1 and Th2, will stay continuously ON (GREEN) to signal the setup is finalized and the sensor is in operation mode.



During setup and operation, please make sure that the sensor is not pointing at a distance longer than the maximum offered range (12.5 meters). Please ensure that a physical object/obstruction (e.g wall) is covering the sensors entire Field of View, no further than the maximum range (12.5 meters) of the sensor.

4.6.3. Operation

Mode 4 enables proximity notification using 3 distance thresholds. As soon as an object or a person completely leaves the light beam of the trigger zone(s) (the measured distance corresponds to the background threshold distance), the switching output is activated. The LEDs will also signal accordingly.

The NO/NC switching output activation time by default is set to 250 ms, and can be modified using the for “NO/NC on time” parameter (see [Section 5.3.7.](#)).

By default, mode 4 offers detection capabilities with a switching window, where the active trigger zone is between Threshold 1 and Threshold 2. By changing the NO/NC active region setting in sensor parameters (see [Section 5.3.4.](#)), the user can also set multiple trigger zones: (1) from min. sensor distance (50 cm) to Threshold 1 and, (2) from Threshold 2 to Background Threshold. Please consult figures below for visual instructions.

 *The NO/NC switching output will not change state until an object (or a person) has completely left the light beam of the selected trigger zone.*

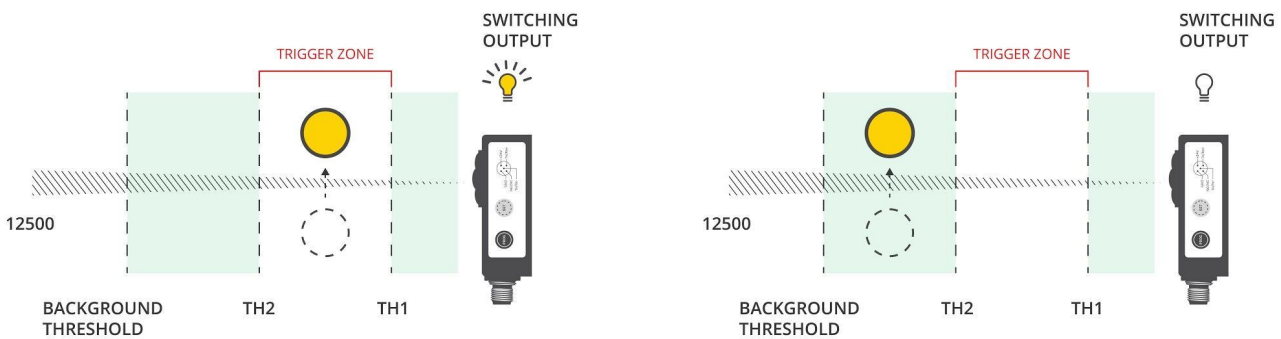

Figure 17. Mode 4 operation (NO/NC active region = 0) ⇒ Only white patched area (Th1 < distance < Th2) is triggering the switching output

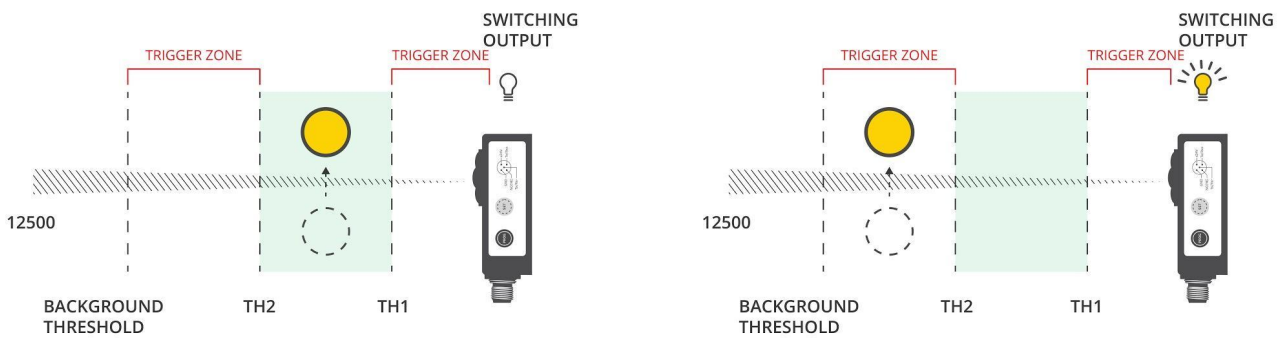

Figure 18. Mode 4 operation (NO/NC active region = 1) ⇒ Only white patched areas (Th2 < distance OR distance < Th1) are triggering the switching output

The following table summarizes possible detection outcomes for mode 4.

Table 11 - NO/NC active region in mode 4

Location of detection	LED indication /	Switching	Switching
-----------------------	------------------	-----------	-----------

	color	output status (NO/NC active region = 0)	output status (NO/NC active region = 1)
Between the sensors minimum distance (50 cm) and the Threshold 1	Th1 blinks RED once	OFF	ON
Between Threshold 1 and Threshold 2	Th1 and Th2 blink GREEN once	ON	OFF
Between the Threshold 2 and the Background threshold	Th2 blinks RED once	OFF	ON
Detection greater than or at background threshold distance	Th1 and Th2 stay continuously ON / GREEN	OFF	OFF

4.6.4. Rolling buffer (5 measurements)

After an object has entirely left the light beam of the trigger zone, the distance that was recorded during detection, is stored in a register as **the measured distance to the object**. The sensor has the capacity to store 5 measurements at the same time. Every new measurement will erase the oldest (5th) value from the device. This functionality allows to obtain accurate distance-to-target feedback as an added layer of intelligence, in addition to the NO/NC switching output. Please refer to [Section 5.2.2.](#) for additional information.

4.6.5. LED signalization sequence

Table 12 - Mode 4 LED signalization sequence

Phase	LED designators	Action	Function
Setup	Th1	LED continuously blinking GREEN	Indicates a properly stored background distance and to signal that the device is ready for Threshold 1 setup
	Th2	LED starts continuously blinking (GREEN)	Indicates a properly stored Threshold 1 distance and to signal that the device is ready for Threshold 2 setup
	Th1	LED continuously on (GREEN)	
	Th1; Th2	LEDs stay continuously ON (GREEN)	Indicates that setup is finalized and sensor is in operation mode.

4.7. Operating mode 5

4.7.1. Description

A trigger zone is created and used to monitor object position proper alignment. A switching output is triggered as soon as an object completely leaves the light beam of the trigger zone(s). Operating mode 5 offers an even more simplified setup process (with respect to previous modes).

4.7.2. Setup

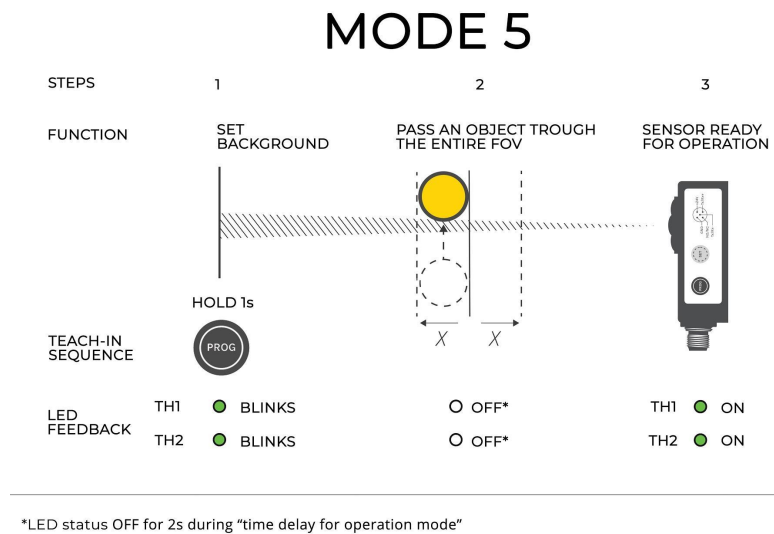

Figure 19. Mode 5 setup phases

Step 1 - Set background threshold

- Make sure an object is fully covering the sensors Field of View at the preferred distance, then hold the PROG button for 1 second.
- The background threshold is now stored and the LED indicators, Th1 and Th2, will start blinking GREEN to signal that the sensor is ready for detection area setup.

Step 2 - Program detection area

- Pass an object through the sensors entire Field of View at the preferred distance.
- After the object has left the sensor Field of View, the minimum distance to the object is registered as a reference. From the registered minimum distance, two symmetric distance limits (corresponding to Threshold 1 and Threshold 2) automatically form the tolerance zone for triggering. Each distance limit is at distance $X = 10$ cm (default value).

- After the trigger zone is created, the sensor will go into “Time delay for Operation mode” for 2 seconds (default), before initializing operation mode. LED indicators, Th1 and Th2, will now turn OFF during the “Time delay for operation mode”.



The “X” distance is programmable via the “LIMIT VALUE” parameter, as described in [Section 5.3.6](#).

Step 3 - Sensor is ready

- Both LED indicators, Th1 and Th2, will turn continuously ON (GREEN), indicating that the setup is finalized and the sensor is ready for operation.



During setup and operation, please make sure that the sensor is not pointing at a distance longer than the maximum offered range (12.5 meters). Please ensure that a physical object/obstruction (e.g wall) is covering the sensors entire Field of View, no further than the maximum range (12.5 meters) of the sensor.

4.7.3. Operation

As soon as an object passes and completely leaves the light beam of the selected trigger zone(s), a switching output is activated. The LEDs will also signal accordingly. The sensor will not be activated while an object or a person stays inside the trigger zone(s) of the light beam.

By default, mode 5 offers detection capabilities with a switching window, where the active trigger zone is between Threshold 1 and Threshold 2. By changing the NO/NC active region setting in sensor parameters (see [Section 5.3.4.](#)), the user can also set multiple trigger zones: (1) from min. sensor distance (50 cm) to Threshold 1 and, (2) from Threshold 2 to Background Threshold. Please consult figures below for visual instructions.

The NO/NC switching output duration time by default is set to 250 ms, but can be modified using the for “NO/NC on time” parameter (see [Section 5.3.7.](#))

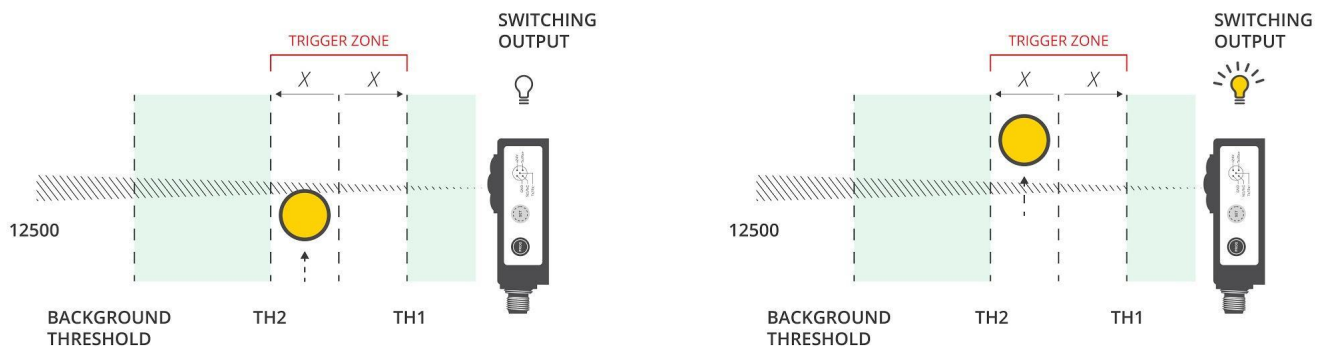

Figure 20. Mode 5 operation (NO/NC active region = 0) ⇒ Only white patched area ($Th1 < \text{distance} < Th2$) is triggering the switching output

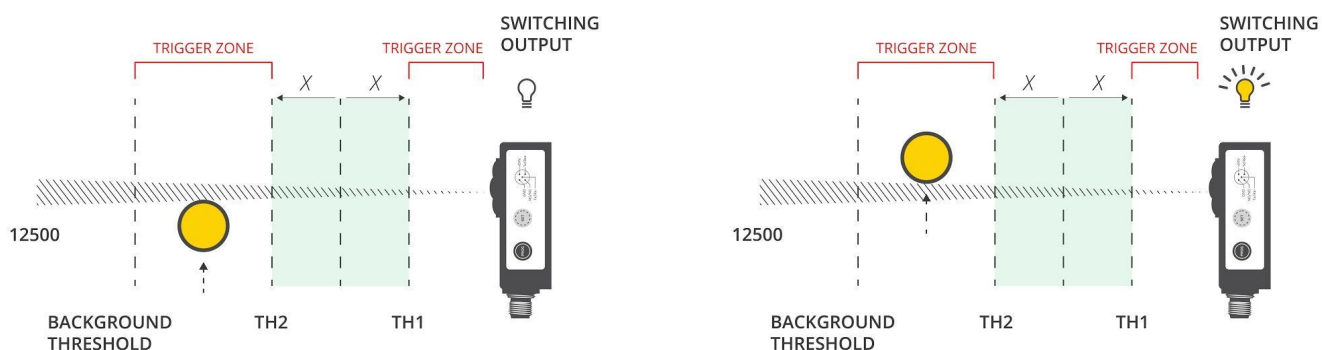

Figure 21. Mode 5 operation (NO/NC active region = 1) ⇒ Only white patched areas ($Th2 < \text{distance}$ OR $\text{distance} < Th1$) are triggering the switching output

The following table summarizes the detection outcomes for mode 5:

Table 13 - NO/NC active regions in mode 5

Location of the detection	LED indication / color	Switching output status (NO/NC active region = 0)	Switching output status (NO/NC active region = 1)
Between the sensors minimum distance (50 cm) and the Threshold 1	Th1 blinks RED once	OFF	ON
Between Threshold 1 and Threshold 2	Th1 and Th2 blink GREEN once	ON	OFF
Between the Threshold 2 and the Background threshold	Th2 blinks RED once	OFF	ON
Detection greater than or at background threshold distance	Th1 and Th2 stay continuously ON / GREEN	OFF	OFF

4.7.4. Rolling buffer (5 measurements)

After an object has entirely left the light beam of the trigger zone, the distance that was recorded during detection, is stored in a register as **the measured distance to the object**. The sensor has the capacity to store 5 measurements at the same time. Every new measurement will erase the oldest (5th) value from the device. This functionality allows to obtain accurate distance-to-target feedback as an added layer of intelligence, in addition to the NO/NC switching output. Please refer to [Section 5.2.2](#). for additional information.

4.7.5. LED signalization sequence

Table 14 - Mode 5 LED signalization sequence

Phase	LED designators	Action	Function
Setup	Th1; Th2	LEDs blinks continuously GREEN	Indicates a properly stored background distance and signals that the device is ready for detection area setup.
	Th1; Th2	LEDs stay continuously ON (GREEN)	Indicates that setup is finalized and sensor is in operation mode.

4.8. Operating mode 6 (Ranging mode)

4.8.1. Description

While calibrated distance data is accessible in all 6 operating modes of the sensor, mode 6 leaves the sensor working as a ranging device, without the use of programmable distance thresholds and trigger zones.

4.8.2. Set up

No setup required. Sensor measures distance data as soon as powered.

4.8.3. Operation mode

The sensor will continuously sample distance data and no other computations are performed. The NO/NC switching output is disabled in mode 6, as well as any LED signalization (TH1 and TH2 LEDs will be steady green except for errors).

The distance data can be read via Modbus function 04: Read input register at address 0 (note that the length to be read is 2, as the “new distance” flag is sent together with the distance data). Please refer to [Section 5.2.](#) for more information.

MODE 6

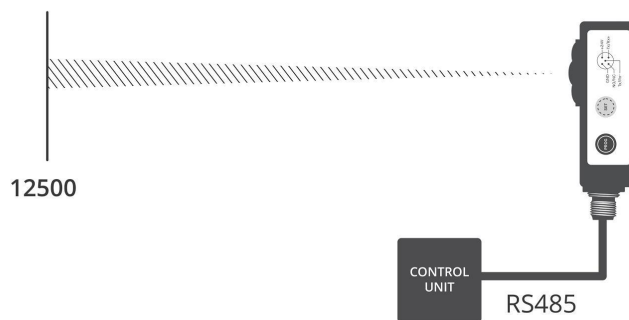

Figure 22. Mode 6 operation

4.9. Switching between modes, threshold transfer

When switching between modes, please note that as soon as the new mode is selected, the sensor will directly go into operation mode without going through the programming phase. Thresholds registered and used in the previous mode will be transferred and automatically applied in the new operating mode. This is especially useful when switching between modes with the same amount of distance thresholds. For instance:

- Switching between modes 1 and 2 (with 1 threshold)
- Switching between modes 3, 4 and 5 (with 3 thresholds)

When switching between modes that use a different number of thresholds, only common thresholds are transferred to the new mode. For example, switching from mode 3 to 1 will keep the background threshold in the previously used mode 3.

In case the user requires to reprogram the thresholds after selecting a new operating mode, this can be done either using the teach-in buttons (PROG and SET) or modifying the following sensors parameters: (1) Background Distance, (2) Threshold 1 Distance; (3) Threshold 2 Distance.

4.10. Error cases

The following table summarizes error cases and the corresponding functions.

Table 15 - Error cases

Error case	Application to modes	Output value	LED signalization
Detection below sensors minimum range (50 cm)	Mode 1 to 6	0x0000	Th1 LED blinks RED until the read distance reaches background threshold again No LED signalization in operating mode 6
Detection beyond sensors maximum range (12.5 m)	Mode 1 to 6	0xFFFF	Th2 LED blinks RED until the read distance reaches background threshold again No LED signalization in operating mode 6
Invalid reading <ul style="list-style-type: none"> - Ambient light too high - Target surface too reflective - Object closer than 50 cm (min. range) - Object too far (beyond 12.5 m) 	Mode 1 to 5	0x0001	Th1 LED stays continuously ON (RED); Th2 LED blinks RED until the read distance reaches background threshold again
Invalid reading applicable only for Mode 6 <ul style="list-style-type: none"> - Ambient light too high - Target surface too reflective - Object closer than 50 cm (min. range) - Object too far (beyond 12.5 m) 	Mode 6	0x0001	Th1 LED stays continuously ON (ORANGE) Th2 LED stays continuously ON (GREEN)



In Operating Mode 6, the only error which is indicated by sensors LED is the "Invalid reading" message. LED indicator, Th1, will stay continuously ON (ORANGE) and Th2 will remain GREEN.

4.11. Special cases (applicable only to modes 3 and 4)

4.11.1. Special case 1

Description

Threshold 1 is set without a physical target (the target being the “Background”), and the Threshold 2 button is set with a target too close to the background distance.

Outcome

The software shall decode the condition as a single zone and automatically activate Operating Mode 1: as soon as an object or a person enters the Field of View of the set threshold area, a switching output is triggered. The sensor is activated as long as an object or a person is in the trigger zone. Both LED indicators, Th1 and Th2 will stay continuously ON (RED) as long as the object is in the Field of View.

4.11.2. Special case 2

Description

Threshold 1 is set with a target (**not** the “Background”) and Threshold 2 is set without moving the target or with a slightly moved target with regards to Threshold 1.

Outcome

The software shall decode the situation as a mode with: 1 Background Threshold and 1 distance threshold. As [Figure 23](#) illustrates only 2 detection zones are created in this case:

- From min. Sensor distance (50 cm) to Threshold 1/2 (referred to as “close” zone)
- From Threshold 1/2 to Background Threshold (referred to as “far” zone)

By default, the active trigger zone (referred to as “Fly Zone”) is set to the close zone. By accessing the “Fly Zone Select” parameter, the user can change the active trigger zone to the far zone. Please refer to [Section 5.3.8.](#) for more details.

The NO/NC switching output will be activated as soon as an object or a person completely leaves the light beam of the selected “Fly Zone” (the measured distance corresponds to the background threshold distance).

The NO/NC switching output duration time by default is set to 250 ms, but can be modified using the for “NO/NC on time” parameter (see [Section 5.3.7.](#))

A detection in the “No-Fly Zone” will blink both LED indicators, Th1 and Th2, once (RED).
A detection in the “Fly Zone” will blink both LED indicators, Th1 and Th2, once (GREEN).

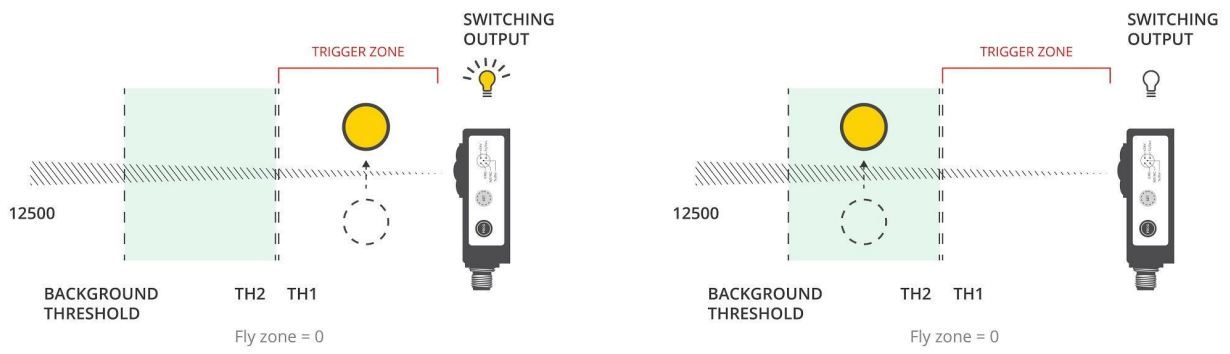

Figure 23. Special case 2 operation (Fly zone = 0) ⇒ Only the “close” zone is triggering the switching output

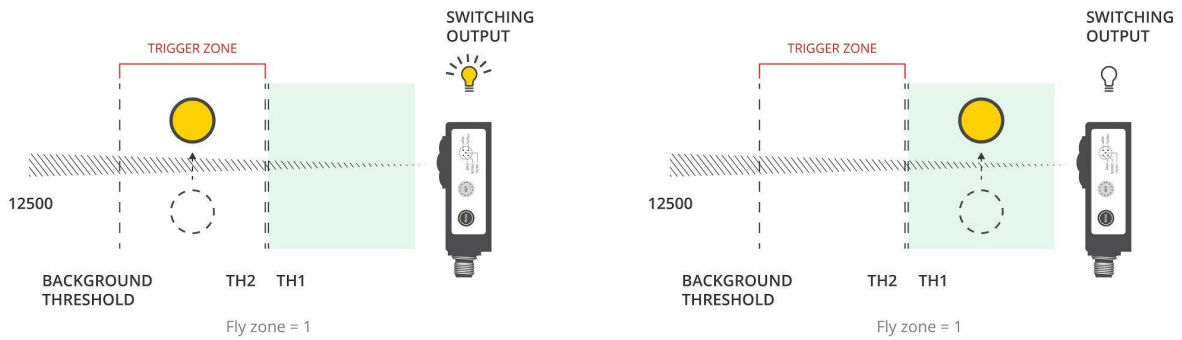

Figure 24. Special case 2 operation (Fly zone = 1) ⇒ Only the “far” zone is triggering the switching output

5. Communication

5.1. RS485 interface settings

The RS485 interface is a **half-duplex connection** with the following parameters:

- ❑ **Baud rate** : 19200
- ❑ **Data bits** : 8
- ❑ **Stop bits** : 1
- ❑ **Parity** : Even

On top of that, a Modbus RTU protocol is in place to handle the data transfer. This is a master-slave type of protocol, ideal for RS485 data communications. This protocol supports up to 247 devices on the bus.

5.2. Input registers (read-only)

Table 16 - Input registers (read only)

Name	Functionality	Address	Length
Distance	Retrieves last read distance along with the new distance flag which specifies whether this is a new distance	0x00	2
Circular buffer	Retrieves the buffer holding the last 5 detection distances	0x02	5

5.2.1 New distance flag

This flag is sent together with the distance data every time. Its purpose is to signal whether the distance data being sent is a new one compared to the last read by the master. This flag is an unsigned 16 bit integer with a value of 0 or 1.

5.2.2 Circular distance buffer (applicable for modes 2, 4 and 5)

This buffer acts as a log for the last 5 detected objects, storing the measured distance to the object. This buffer has to be read entirely every time (length 5), otherwise an error will be returned.



Please note that the distances logged in this buffer are stored independently of the selected trigger zone and threshold values.

5.3. Configurable sensor parameters (holding registers)

The following section lists holding registers of configurable sensor parameters, their functionality and corresponding Modbus commands for execution.



It is important to use 120 Ohm resistors at both terminations of the RS485 bus for proper operation.

5.3.1. Device addressing setting

This parameter holds the device address. For changing this parameter, a broadcast command must be sent. For that, please use the following configuration::

Slave ID : 0 (for sending broadcast command)

Address location : 0

Value : 1 to 247

Example: 0x00 0x06 0x00 0x00 0x00 0x01 0x49 0xDB

This sets the address of all devices on the bus to 1

For reading back the address of a device, the slave ID must be the same as the device address. Please reference the example below:

Slave ID : 1 to 247

Address location : 0

Value : read-only (1 to 247, default 1)

Note:

The slave can't reply to the master in broadcast mode.

5.3.2. Menu timeout

This parameter defines the timeout when in Programming mode. For example, if a user has set the background threshold (PROG), but fails to set valid TH1 and/or TH2 limits within this time limit, the device goes back into operation mode. By default the time window is 30 seconds.

Slave ID : 1 to 247

Address location : 2

Value : 5 to 300 (in seconds, default 30)

5.3.3. Time delay for operation mode

This parameter defines the time delay between the end of the programming (valid thresholds are set) sequence and the device going into operation mode. Extending the time delay parameter can be useful in cases when more time is required for preparing the operation environment.

Slave ID : 1 to 247
Address location : 4
Value : 2 to 300 (in seconds, default 2)

5.3.4. NO/NC active region (applicable to mode 3, 4 and 5)

This boolean parameter defines the trigger zone(s) for the NO/NC output.

NO/NC ACTIVE REGION = 0: when trigger is detected between the Threshold_1 and Threshold_2, the NO/NC output is activated.

NO/NC ACTIVE REGION = 1: when the trigger is detected below the Threshold_1 or between the Threshold_2 and wall, the NO/NC output is activated.

Slave ID : 1 to 247
Address location : 10
Value : 0 or 1 (default 0)

Note:

Not applicable to operating modes 1 and 2, as they only implement a single Background Threshold). In these modes, the NO/NC output will be triggered on every detection within the selected trigger zone.

5.3.5. Operating mode select

Selects the sensors operating mode.

Slave ID : 1 to 247
Address location : 14
Value : 1 to 6 (mode 1=1, mode 2=2, mode 3=3, mode 4=4, mode 5 =5, mode 6=6)

5.3.6. Mode 5 limit value select

This parameter defines the size of the detection zone for operating mode 5 only. The detection area is created using object distance +/- the limit value. Default distance is 10 cm for each distance limit.

Slave ID : 1 to 247
Address location : 16
Value : 50 to 1000 (in millimeters, default 100)

5.3.7. NO/NC on time (applicable to mode 2, 4 and 5)

This parameter defines the amount of time the NO/NC switching output will remain triggered. Default value is 250ms.

Slave ID : 1 to 247
Address location : 18
Value : 50 to 1000 (in milliseconds, default 250)

Note:

Not applicable for operating modes 1 and 3. In these modes the NO/NC is triggered as long as there is a detection within the selected trigger zone.

5.3.8. Fly zone select

Selects the NO/NC trigger zone for special case 2. A value of 0 sets the fly zone to the closer zone, while a value of 1 sets it to the far zone

Slave ID : 1 to 247
Address location : 20
Value : 0 or 1 (default 0)

5.3.9. NPN/PNP selected

This parameter defines whether the switching output is sourcing (PNP) or sinking power (NPN). An example of NPN/PNP connection is available in [Section 7](#). **The default setting value is 1 (NPN).**

Slave ID : 1 to 247
Address location : 24
Value : 1 or 2 (value 1 for NPN and 2 for PNP select, default 1)

Note: Requires sensor restart.

5.3.10. NO/NC selected

This parameter defines whether the switching output is in a normally open (NO) or normally closed (NC) configuration. A value of 0 sets it to NO, while a value of 1 sets it to NC. **The default setting value is 0 (NO).**

Slave ID : 1 to 247
Address location : 26
Value : 0 or 1 (value 0 for NO and 1 for NC select, default 0)

5.3.11. Background distance

This parameter holds the background distance. The following cases apply: (1) the parameter can be read back after using the teach-in buttons to program the device; (2) it can be programmed using Modbus function 06 Write single register.

Slave ID : 1 to 247
Address location : 28
Value : 500 to 12 500 (in millimeters, default 0)

5.3.12. Threshold 1 distance

This parameter holds the threshold 1 distance. The following cases apply: (1) the parameter can be read back after using the teach-in buttons to program the device; (2) it can be programmed using Modbus function 06 Write single register.

Slave ID : 1 to 247
Address location : 30
Value : 500 to 12 500 (in millimeters, default 0)

5.3.13. Threshold 2 distance

This parameter holds the threshold 2 distance. The following cases apply: (1) the parameter can be read back after using the teach-in buttons to program the device; (2) it can be programmed using Modbus function 06 Write single register.

Slave ID : 1 to 247
Address location : 32
Value : 500 to 12 500 (in millimeters, default 0)

5.4. Default factory reset

The sensor can be reverted back to its default settings (configurable sensor parameters) at any time. This can be done using the following Modbus-like serial command:

{Slave ID} 0xFF {CRC16-Modbus}

Example for Slave ID 1 (default): 0x01 0xFF 0x40 0x60

To confirm that the reset has been successful, The LED indicators, TH1 and TH2 will blink GREEN and RED alternatively 10 times, and then both indicators will change its status to continuous ON (GREEN). The sensor will reply via RS485 interface, Modbus-like format (its own address + 0xFF + CRC16-Modbus) with a slave ID 1.

6. Optical characteristics

6.1. Projected reception area

Terabee IND-TOF-1 is an optical distance measurement sensor, that uses infrared Time-of-Flight principle. The sensor features a 2 degree Field of View, which corresponds to a detection area of 3.5 cm (spot diameter in reception) at 1 m range, 10.5 cm (spot diameter) at 3 m range, and scales linearly with distance. Figure 25 illustrates spotlight geometry of the sensor at different reference distances.

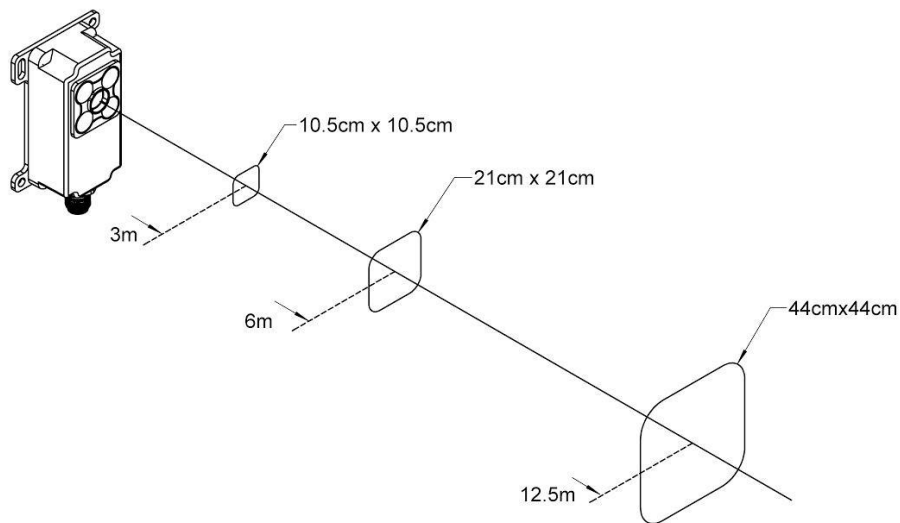

Figure 25. IND-TOF-1 spot light geometry (reception) at 3m, 6m and 12.5m reference distance

6.2. Field of View characteristics

Due to the open Field of View nature of the sensor, multiple targets can be detected simultaneously, causing an averaging effect. Figure 26 shows an example of this phenomenon.



Please consider that inconsistent reading might occur when putting multiple objects at different distances in the sensor Field of View or attempting to detect small (smaller than the Field of View) or irregularly shaped objects. For best results, the measured object shall fill the entire Field of View of the sensor.

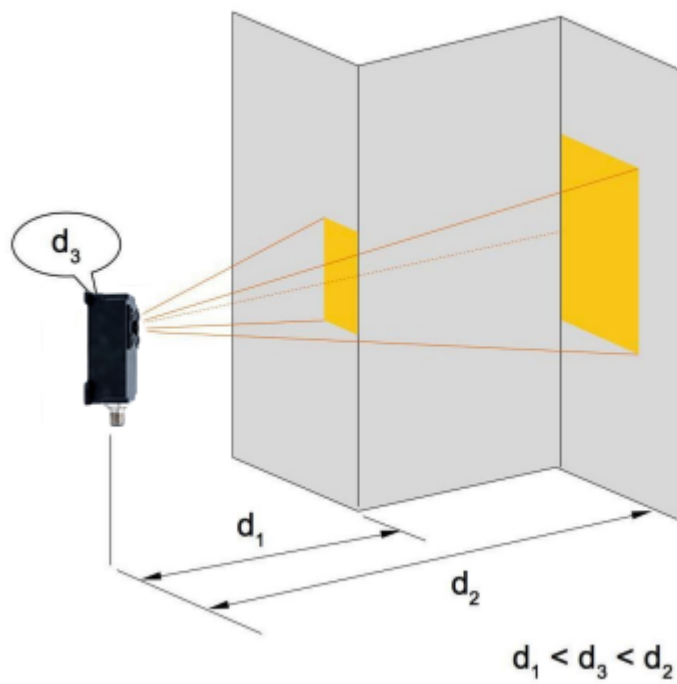

Figure 26. Example of distance averaging effect (d_3) due to multiple objects in sensor Field of View and at different real distances (d_1 and d_2).

7. Connection example: input to a PLC

7.1. PNP connection

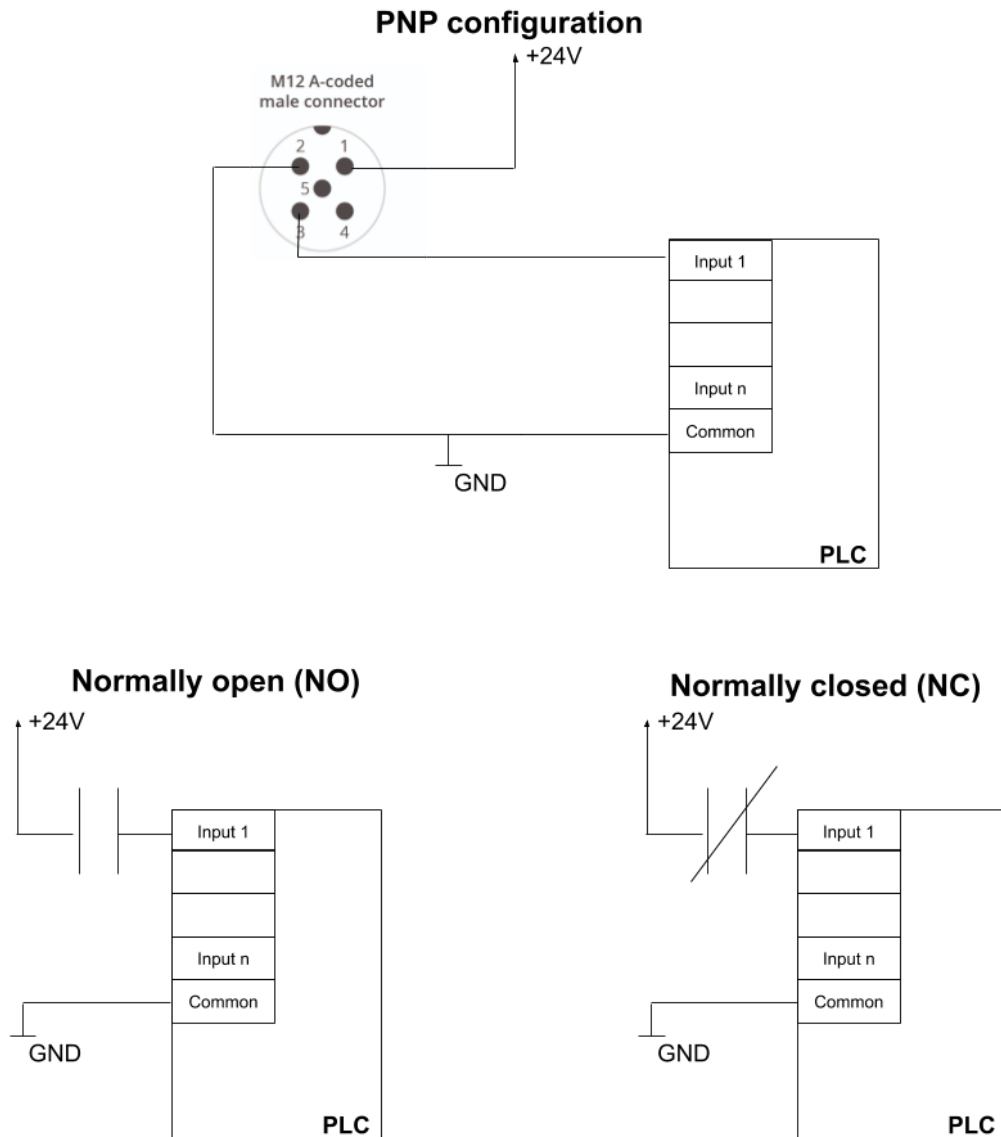

Figure 27. Example of PNP connection (top) for NO/NC schematics (bottom)

7.2. NPN connection

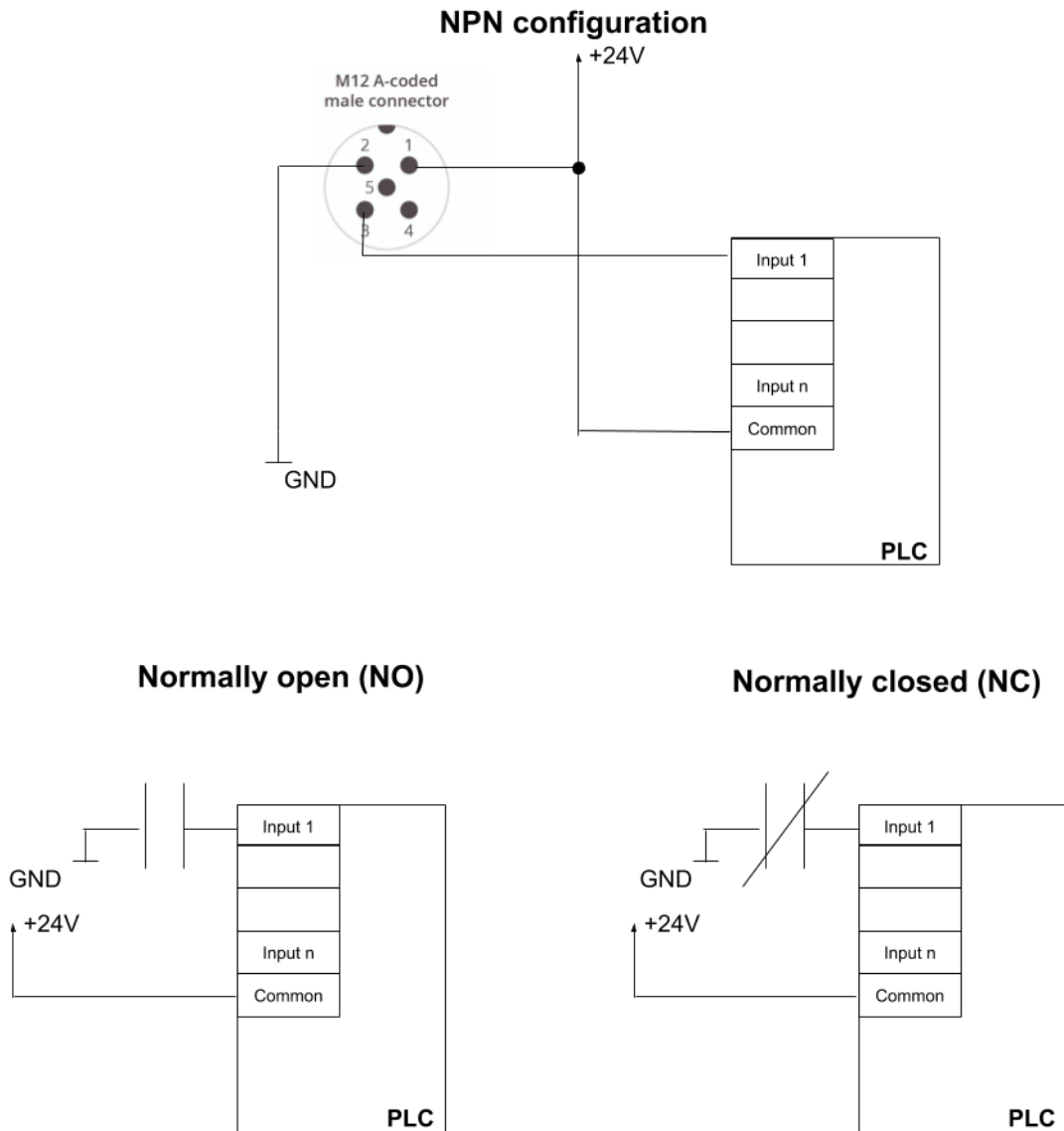

Figure 28. Example of NPN connection (top) for NO/NC schematics (bottom)

8. Compliance

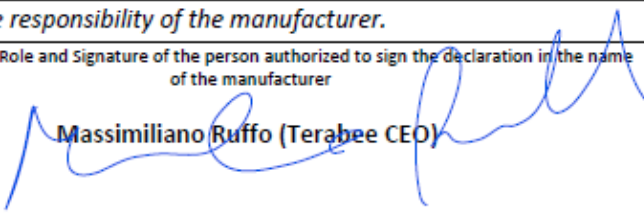
EU Declaration of Conformity	
<i>The manufacturer:</i>	Terabee
<i>settled in:</i>	St. Genis Pouilly, France
<i>Vat Number:</i>	FR38789459179
<i>Declares that the Appliance</i>	
<i>Type and/or Model</i>	IND-TOF-1 October 2019
<i>Description:</i>	Distance sensor based on Time of Flight technology
<i>Function:</i>	Industrial automation and robotics applications
<p><i>Provided that it is installed, maintained and used in the application for which it is made, with respect of the « profession's practices », relevant installation standards and manufacturer's instructions, is in conformity with the relevant European Union harmonisation legislation and specifically:</i></p>	
Directives	
2014/30/UE	EMC -Electro Magnetic Compatibility
2011/65/UE	RoHS
Main requirements and/or reference standards used:	
CEI EN 61000-6-1:2007	CEI EN 61000-4-6:2014
CEI EN 61000-6-2:2006	CEI EN 61000-4-20:2013
CEI EN 61000-6-3:2007+A1:2013	CEI EN 62471:2010
CEI EN 61000-6-4:2007+A1:2013	EN 60068-2-27:2009
CEI EN 61000-4-2:2011	EN 60068-2-6:2008
CEI EN 61000-4-8:2013	EN 60068-2-64:2008
CEI EN 61000-4-11:2006	CEI EN 60529
CEI EN 61000-4-3:2007 + A1:2009 + IS1:2010 + A2:2011	
CEI EN 61000-4-4:2013	
CEI EN 61000-4-5:2016+A1:2018	
<i>This declaration of conformity is issued on the sole responsibility of the manufacturer.</i>	
<p><i>Place and date</i></p> <p>St-Genis Pouilly (France) October 2, 2019</p>	<p style="text-align: center;"><small>Name, Surname, Role and Signature of the person authorized to sign the declaration in the name of the manufacturer</small></p> <p style="text-align: center;">Massimiliano Ruffo (Terabee CEO)</p> 

Figure 29. EU Declaration of conformity with compliance to standards and used directives